

TASMANIAN HARDWOOD STRIP FLOORING ON JOISTS

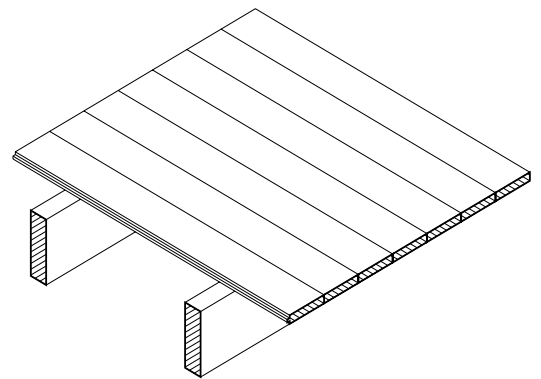

installation guide

These instructions apply to quality Tasmanian strip flooring fixed over joists in residential applications.



STRIP FLOOR ON JOISTS

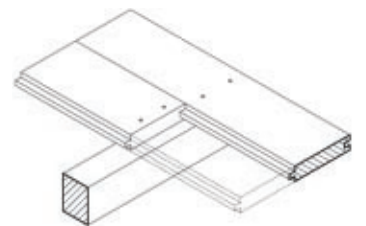

TOP NAILED

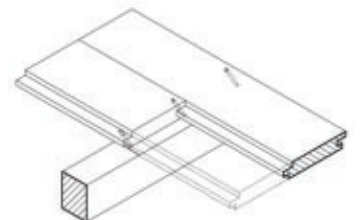

SECRET NAILED

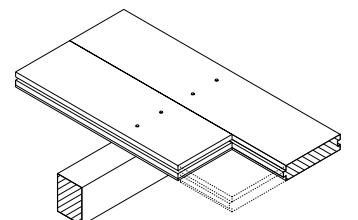

END MATCHED

TOOLS

Simple tools are adequate in most applications.

Necessary tools are:

✓ Tool Requirement Checklist		✓	
	Pencil, tape measure and square		Hammer, punch and nail bag
	Stringline, spirit level and straight edge		Hand saw and jig saw
	Safety glasses, dust mask and knee pads		Spacers (about 100mm long and 2 mm thick)
	Rubber mallet, broom and vacuum cleaner		Framing chisel

For specialist applications, a drop saw, an air power staple gun, a power actuated fastener system and a cramping system may be useful.

MATERIALS

Use quality boards of the correct thickness.

Grade descriptions for strip flooring are set out in the Australian Standard AS 2796 and are available at: www.tastimber.tas.gov.au. Boards at least 19 mm thick are needed to span 450 mm.

Board width - *Only secret nail boards up to 85 mm cover width.*

Secret nailed flooring is fixed through the tongue of specially profiled boards. Since they are only secured with one fastener per joist or batten, their width is limited to 85 mm cover. Board over 85 cover must be top nailed with two fasteners per joist.

Use the correct nails for the job.

The nail sizes required by Australian Standard 1684 are:

Nail sizes for T & G flooring to joists*		
Nailing	Softwood joists	Hardware & cypress joists
Hand driven	65 x 2.8 mm bullet head	50 x 2.8 mm bullet head
Machine driven	65 x 2.5 mm	50 x 2.5 mm

Nail sizes for T & G flooring to plywood substrate*	
Strip flooring thickness (mm)	Rec. nailing (min.15mm substrate)
19 or 20	38 x 16 guage chisel point staples or 38 x 2.2 mm nails at 300mm spacing
12,19 or 20	32 x 16 guage chisel point staples or 30 x 2.2 mm nails at 200mm spacing

*Alternative fasteners can be used for substrates types not listed subject to manufacturers' recommendation.

Any glue used is in addition to the correct nailing. Use only specialist elastomeric glues.

Where vibration or dynamic loading is of concern, gluing the flooring to the joists may reduce later movement. Even if glued, the floor still needs to be fully nailed. *Do not use hard setting glues.*

MOISTURE CONTENT OF THE TIMBER

Timber is a natural product. Its dimensions vary with changes in surrounding moisture.

As timber absorbs moisture to remain in equilibrium with its surrounding atmosphere, it expands. As it loses moisture, it shrinks. Strip flooring will always move slightly between boards as the ambient conditions of the surrounding environment change. So, to produce a successful timber floor, the timber needs to be installed at the correct moisture content, changes in the ambient conditions controlled and any movement accommodated.

The moisture content of the timber at time of laying is very important.

Test the moisture content (MC) of at least 5 randomly selected boards with a resistance moisture meter when the timber is delivered or insist the supplier provides readings. Readings from the meter must be corrected for species and temperature with correction factors available at: www.tastimber.tas.gov.au.

Australian Standard AS2796 requires moisture contents between 9 and 14%. Laying material that is too wet or too dry may cause problems later.

If necessary, allow the timber to acclimatise to long term service conditions.

Typically, timber supplied to the Standard should have a moisture content suitable for normal temperature and humidity conditions in most locations.

Where service conditions vary considerably from normal, such as in air-conditioned, centrally heated or hot sunny rooms, the timber should be acclimatised by racking it out in the room with strips between each row of boards. The timber should be left with the heating or air conditioning running, until the moisture content is satisfactory.

The more the expected service conditions in the room vary from normal, the longer the boards need to be acclimatised.

Timber	Service Environment	Response and Required Action
Flooring supplied at a moisture content usually between 10% and 12 %	Moist Conditions Average MC between 12.5–16% Cool & damp or hot & very humid	Timber expands <ul style="list-style-type: none"> • Provide extra expansion joints • Acclimatise
	Normal Conditions Average MC between 10–12.5%	Timber remains relatively stable.
	Dry Conditions Average MC between 8–10% Air conditioned, centrally heated, or rooms with large northern windows	Timber contracts <ul style="list-style-type: none"> • Acclimatise • Consider alternatives to polyurethane finishes

STORAGE

Protect the timber from moisture during all stages of construction.

Avoid exposing the timber to rain, dew or direct sunlight. Keep it away from the ground or newly laid concrete. Repair damage to pack covers immediately.

The flooring should be stored in a fully enclosed area where it is to be laid, or in a similar environment.

Handle the timber carefully.

Protect the upper surfaces and the tongues of the boards from damage.

PREPARATION

Only install the flooring in a fully weatherproofed building.

The roof should be on, windows & external doors installed, exterior cladding finished and wet trades complete. The storm water system must be complete or effectively taking water away from the sub-floor or slab.

Do not lay the floor if there is any sign of water entering the work area.

Provide under floor ventilation to the requirements of the Building Code of Australia as a minimum.

The ground under the floor should be dry and the sub-floor well ventilated. In renovation projects, clear existing ventilators or install additional ventilators in the perimeter walls.

Where conditions under the floor are damp & the potential for additional drainage or ventilators limited, install a continuous impervious plastic membrane over the ground and fixed up the perimeter walls. Lap and tape the joints. The space above this barrier must still be ventilated.

Floor framing should be solid, level, true and preferably seasoned.

The tops of framing members should be flat & sound. Place a 3 m straight edge along & across the top of joists. Variation should not exceed 3 mm. Plane proud joists & pack low ones.

Install required insulation and draught barriers.

The Building Code of Australia now includes thermal performance requirements for housing. Complying with these may involve insulating the timber floor. The major insulation options are:

- Reflective and moisture permeable foil draped over the joists, or fixed underneath them.
- Bulk insulation, such as insulation batts, packed between the joist on the foil or other support such as wire mesh.
- Proprietary folded foil and expanded foam products fixed between the joists.

Details of these options and the rating achieved are available at: www.tastimber.tas.gov.au.

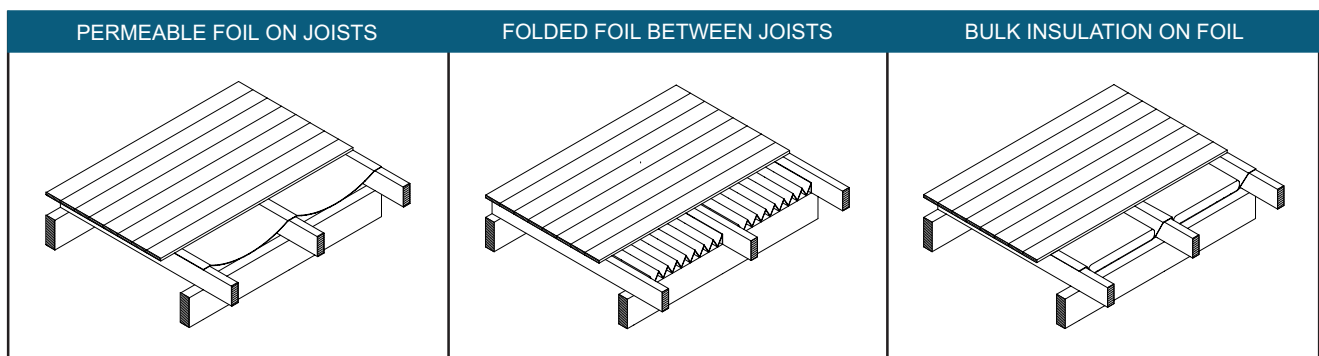

Keep the site and work area clear and clean.

Clean and vacuum the substrate. Arrange the work area so that sawdust from cutting boards is excluded from where boards are laid. Put unneeded tools away.

SANDING & COATING

Prepare the floor thoroughly.

The quality of the finished timber floor depends heavily on the quality of the surface preparation. Ensure that all exposed nails are punched adequately. Fill any holes or gaps with a filler compatible with the floor finish.

Select the coating system to suit the project.

Moisture curing & 2 pack polyurethanes produce a clear, very hard-wearing surface in a matt, satin or high gloss finish. However, they darken with age. If applied to a poorly laid or unstable floor, they can also glue the tongue of one board into the groove of the next.

Water-based polyurethanes can produce a clear, hard-wearing surface in a matt, satin or gloss finish. While more expensive, they produce less fumes during application & curing, & are trafficable earlier. They can also glue boards in an unstable floor together.

Modified oil coatings are clear varnishes, generally made from a mixture of resin & oil. Easy to apply & penetrating, these give a slightly softer look than polyurethanes but are less hard wearing & darken with age. A surface polish is recommended to reduce maintenance in high traffic areas.

Oils are penetrating finishes that are generally less hard wearing than the modified oils or polyurethanes. They give a soft, natural appearance but require regular maintenance.

Employ professional sanding and finishing contractors.

The floor needs to be sanded to a flat & level surface. Deep scratch marks should not be present or accepted. Equally, do not expect a "furniture quality" finish on site.

FINISHING

Follow the finish manufacturer's instructions exactly.

Many problems with timber floors are due to inappropriate application of the finish. Do not thin the finish unnecessarily. Only apply polyurethane or two part coatings to tight, well-laid floors at the correct moisture content.

These coatings can glue boards together, causing 'clumping', 'slabbing' or other problems later.

CARE

Fit protective pads to your furniture.

Timber floors are resilient but they can be scratched by moving furniture or high point loads. Inspect the bottom of lounges, chairs and sideboards. Some older furniture has metal buttons on the base of legs. Remove these. Fit adhesive felt and other soft pads to all legs and supports that will sit on the floor. The hard plastic feet on some stools can dent the timber. If this occurs, fit softer rubber pads.

Minimise dust.

Dust on the floor can scratch the surface of the finish, especially in high traffic areas. Install coir mats at doors. Vacuum and sweep regularly.

Wipe off marks with a damp cloth.

Most marks can be removed without the use of abrasives or chemicals. Do not wet mop the floor as it can lead to problems with the timber.

Clean up spills quickly.

Occasional spills should not significantly influence the floor if they are wiped up immediately. Persistent leaks from sinks or dishwashers will cause problems. They should be fixed immediately.



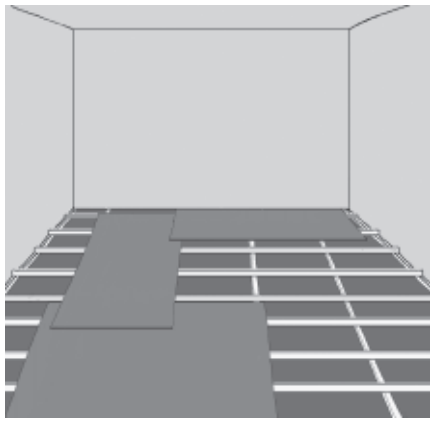

ONE

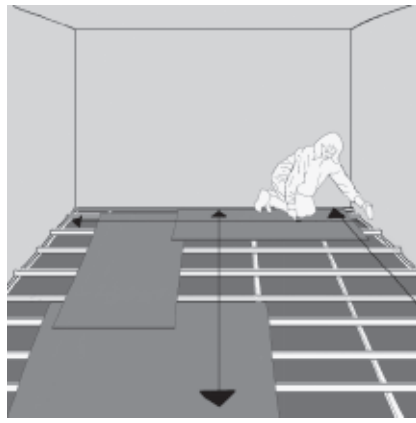

TWO

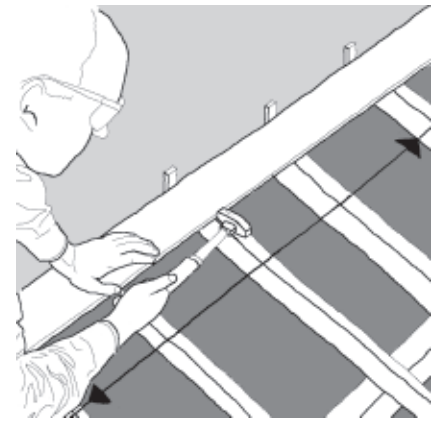

THREE

INSTALLATION

Keep the site and work area clear, clean and safe.

Sweep the top of the joists.
Put unneeded tools away.
Arrange the work area so that sawdust from cutting boards is excluded from where boards are laid.

Establish a safe temporary working platform and walkways over the open floor joists. These can be repositioned or removed as the floor is laid.
Install any insulation or draught barrier.

Set out the exact line of the boards.

Use a string line, tape and square to check that the sides of the room are parallel.

Decide on the exact line of the rows of boards to suit the room's shape. Remember that boards need to span as near to right angles to the line of the joists as possible.

Set this line out and mark it as the string line near the centre of the room.

Set up a second string line at least the width of two boards away from the wall. This line **MUST** be exactly parallel to the reference line in the middle of the room.

Plan expansion gaps at the perimeter of floors & intermediate gaps in floors over 6m wide.

A min. 10mm gap is needed between the edge of the boards & any vertical barrier such as walls.

Floors over 6m wide need intermediate expansion gaps at a rate of 10 mm per 6 m width across the boards. These can be located at thresholds or spaced evenly throughout the floor as a series of smaller gaps.

Use 2mm spacers between rows of boards about 1.2 m apart to form these expansion gaps.

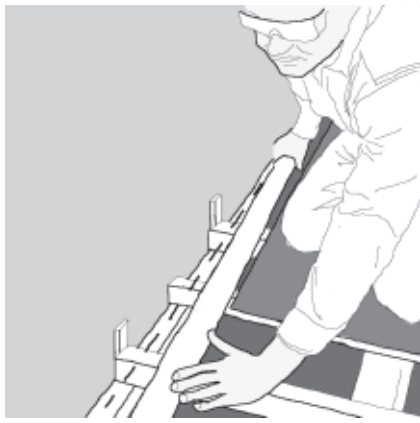

FOUR

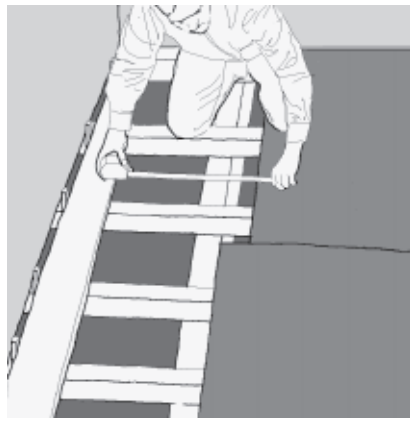

FIVE

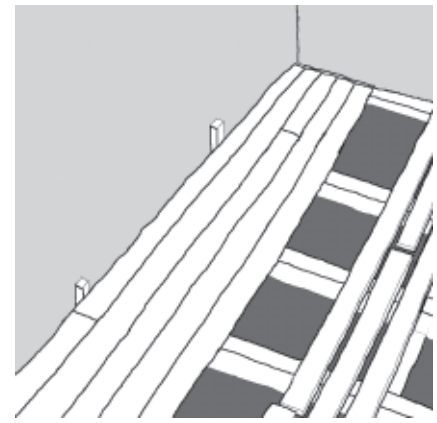

SIX

INSTALLATION

Set out the first board carefully.

Select long straight boards for the first row.

For boards that are not end matched, square cut them so that butt joints occur at the centre of the joists. The boards must bear at least 12 mm onto the joist.

If the end wall is not parallel to the string set out line, profile the boards so that any remaining gap is covered by the skirting board.

Position the first row of boards approximately in place, parallel to the set out line. Check that the expansion gap is sufficient. Make sure the boards clear any obstructions.

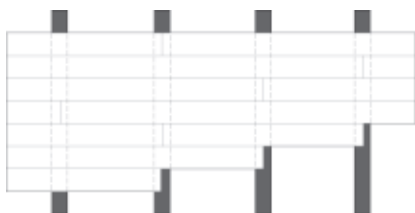

Fig 1. Butt joints over joist for boards that are not endmatched.

Install the first board carefully.

Starting from one end of the row, position the end of the first board in exactly the right position, leaving the necessary expansion gap.

Single nail that end in place. If top nailing, do not drive the nail home.

Carefully measure the distance from the string set out line to the fixed end of the board.

Move to the other end of the board and position it at exactly the same distance from the set out line. Fix it into place.

Repeat this at the centre of the same board, then at each joist.

Continue with next board in the row until the first row is complete and solidly fixed in place. Ensure any butt joints are tight.

If necessary, use packers to block this row off the end wall so that it will not move as subsequent rows are cramped into position.

Lay boards in straight & parallel lines.

Cut and arrange about 5 to 8 full rows of boards ready for laying.

Sort the boards so that butt joints in adjacent rows are a minimum of 450 mm apart and are distributed evenly throughout the floor.

With end matched boards, position site-cut ends near the wall. Use the full length and the machined ends of boards where possible.

Ensure joints in adjacent rows of end matched boards do not fall in the same joist spacing.

Boards need to be at least two joist spacings long. Use shorter pieces at the ends of the rows.

Select boards to spread any colour variation evenly through the floor.

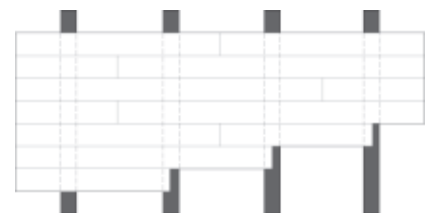
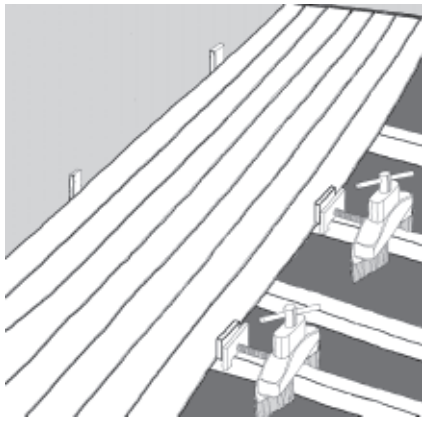
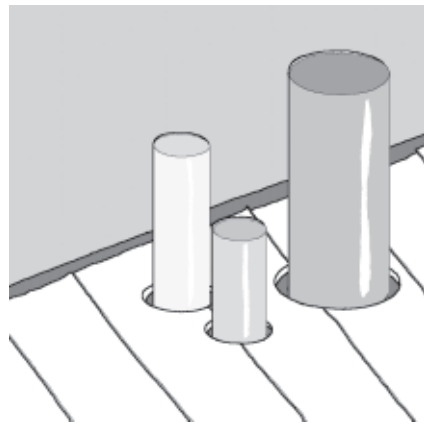

Fig.2. Butt joints for end matched boards.



SEVEN



EIGHT



NINE

INSTALLATION

Position boards carefully and cramp tight.

Top nailed boards can be clamped with a cramping system, or with a chisel.

Always protect the tongue of the board with an off cut. If using a cramping system, cramp no more than 800 mm width of flooring at a time. If clamping with a chisel or other hand lever, cramp no more than 5 rows of boards at a time.

Cramp boards tight working from one end of the row closing any gaps.

As the boards are cramped, knock the top surface of the boards with a rubber mallet. This helps seat the tongue and groove home.

Nail the leading board at each joist as it is cramped.

Again do NOT drive the nail fully home.

Ensure all butt joints are tightly closed. Push them in from the end if necessary.

For secret nail boards, cramp each board tight or use specialist fastening guns. Fully nail them as they are laid.

Cut around any pipes or penetrations.

Mark the boards carefully and cut them with a hole or jig saw. Boards should finish 10mm clear of the penetration or pipe.

Use the correct number and length of fasteners.

Australian Standard 1684 establishes min. fastener dimensions for fixing flooring to joists. These are set out in the *Materials* section above.

Boards over 85 mm cover width **MUST** be surface nailed with two nails per joist.

If glue is used, it must be additional to the correct nailing.

Gluing the flooring to the joists is generally not necessary. If it is glued, the flooring still needs to be fully nailed.

Only use specialist elastomeric glues. Do not use hard setting glues

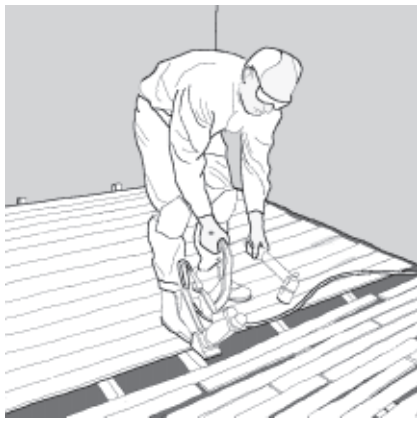

TEN

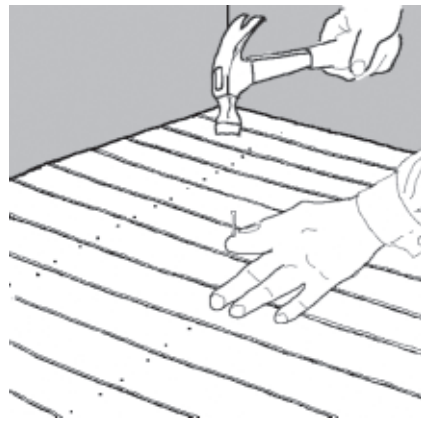

ELEVEN

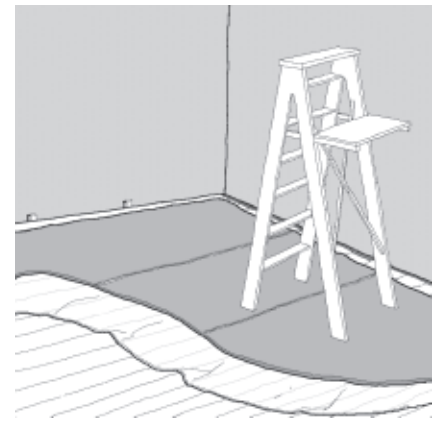

TWELVE

INSTALLATION

Repeat the process until the floor is complete.

Incorporate intermediate expansion gaps if they are required.

For surface nailed boards, the floor must now be fully nailed.

Boards should be in full contact with the floor frame as they are nailed.

Keep the nail lines straight. Skew consecutive nails in opposing directions.

Nail at least 12 mm from the end of boards. Depending on the species, nailing near the end may cause splitting. If this occurs, pre-drill those nail holes to 80% of the nail diameter.

Take care driving the nails home, as a missed swing of the hammer may dent the timber.

Prepare the floor thoroughly.

The quality of the finished timber floor depends heavily on the quality of the surface preparation.

Punch all exposed nails a minimum of 3mm below the surface of the boards.

Fill the nail holes with a filler compatible with the floor finish.

Protect the boards prior to sanding and finishing.

Plasterboard setting compounds can stain timber & silicone sealants and glues can affect the bond of the finish.

Scaffolding, ladders, & dropped tools can dent timber significantly.

Cover the completed floor with cardboard, plastic and drop sheets.